

A photograph of an industrial facility featuring several large, vertical, cylindrical tanks or drums. The tanks are painted a light grey or silver color and are surrounded by a complex network of metal scaffolding, walkways, and pipes. The scene is set against a clear blue sky. A green horizontal band is overlaid across the middle of the image, containing white text. Below the green band is a white diagonal banner containing green text. At the bottom of the image, the Questtec logo is visible, consisting of the word 'Questtec' in a large, white, sans-serif font and the word 'SOLUTIONS' in a smaller, white, sans-serif font below it.

LEVEL-TRAC & STEAM-TRAC

HRSG Drums, Boilers, Heaters, De-Aerators, Condensers Level Gage
and Level Switch Direct and Indirect Per PG60.1

Questtec
SOLUTIONS

LEVEL-TRAC & STEAM-TRAC

TURBINE

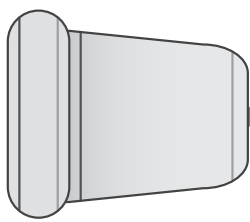

TWIP
 Heater Drains
 Reheat Line Drains
 Superheat Line Drains
 Drip pots downstream of attemperator

BOILER

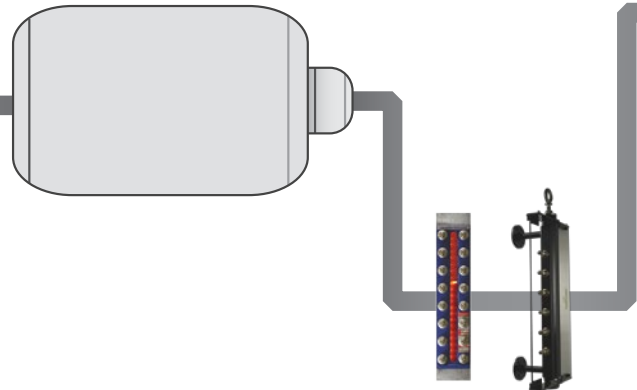

WATER LEVEL MEASUREMENT

THE PRINCIPLES UNDERLYING THE PRODUCT

Reliable detection of condensate levels within boiler drums is one of the most critical measurements required in a steam generation plant. Low condensate levels can damage boiler tubes while high condensate levels can damage steam turbines. These are catastrophic events that result in significant maintenance costs, but are fully preventable with the right safeguards.

Fortunately, steam and condensate have distinct electrical properties. Condensate is far more conductive [and less resistive] than steam. Boilers produce a wide range of condensate conductivities within their drum and piping systems. These simple properties can be leveraged to provide accurate, reliable measurement of condensate levels through two different approaches: conductivity and resistivity. Questtec offers both in our indirect gages.

CONDUCTIVITY

The conductivity approach utilizes a series of switches to determine the drum's condensate level. A control unit houses detection modules that deliver a low voltage signal to probe tips in a water column. When a probe tip is submerged in condensate, its circuit is completed and two sets of DPDT "Form C" Dry contacts change state. By reading the probes switches and noting their locations, the condensate level is apparent.

The Level-Trac LT-100 Series is based on this principle and supports any number of horizontally or vertically mounted probes. The standard control units come in 50 kΩ sensitivity, and are also available in 25 or 75 kΩ. The 11 pin module plug in design is easily replaceable in the field by hand. An optional remote indicator may be mounted up to 500 ft away in a Fiberglass Reinforced Polycarbonate Nema-4X enclosure or control panel mount.

RESISTIVITY

The resistivity approach is a more technically nuanced approach that measures electrical resistance to determine condensate levels. Resistivity between condensate and steam is measured in a calibrated cell of the water column. The cell dimensions create a calibrated resistance typically greater than or equal to 0.1 MΩ when condensate is absent. When condensate is present, the resistance in the cell drops below 0.1 MΩ. A resistivity circuit is arranged to sense whether the probe resistance is less than or greater than the 0.1 MΩ mark within a series of cells to determine how many contain condensate. The condensate level in the drum becomes apparent in a manner similar to the conductivity system. The detection level is independent of water purity and boiler operating conditions.

The Level-Trac LT-210, 220, and 310 Series Electronics are based on this principles. As there is a continual live signal on every channel, this system offers engineered redundancy with fault tolerant fail safe operation. A push-to-test button completely tests the electronics integrity and system's operation, a feature that aids in troubleshooting. Questtec can fulfill your level measurement needs on the principle of conductivity or resistivity.

Conductivity

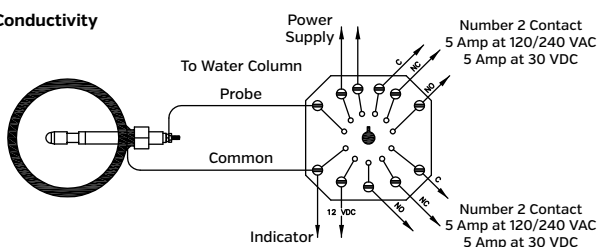

Resistivity

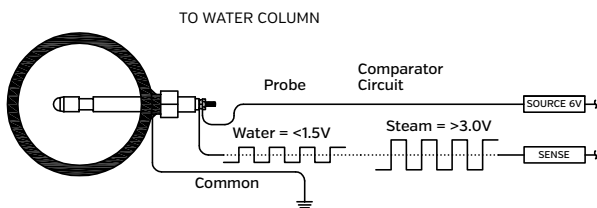

LEVEL-TRAC & STEAM-TRAC

HEATERS

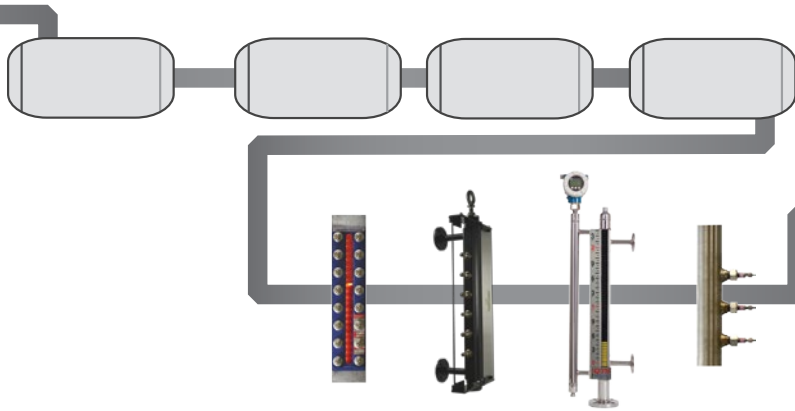

DEAERATOR

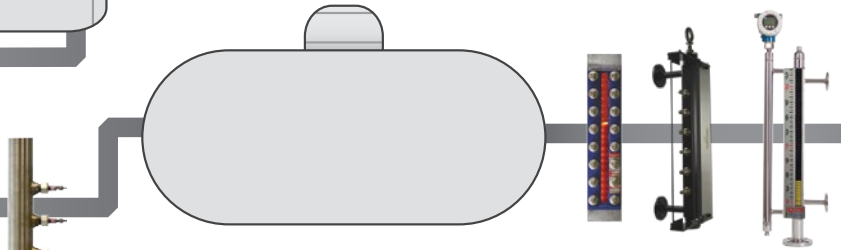

TURBINE WATER INDUCTION PREVENTION

DIRECT AND INDIRECT PER PG60.1

All normally operating steam turbines carry the inherent risk of water ingress. Small amounts of condensate can enter from any connection to the turbine, sometimes arising rapidly from the condensation of steam. This almost always results in catastrophic damage to the turbine, even in low pressure situations. Human operators are rarely able to recognize and prevent these problems as quickly as they occur. Therefore, automatic turbine water induction prevention (TWIP) systems must be used to safeguard turbines from this danger. They save significant costs through quick detection and prevention of water ingress into the steam turbine.

THE QUESTTEC SOLUTION

Questtec offers a range of products to safeguard your system with TWIP. Safe plant operation begins with a 12 Probe Level-Trac LT-220 system installed on the boiler drum with high alarms and high trips set and continues with the LT-310 on Heater Drains, Superheat and Reheat Main Drains, and on Drip Pots downstream of Attemperators. This will monitor all potential areas for turbine water induction and automatically detect it. Our products fulfill ASME recommendations for safe steam turbine operation made in the TDP-1-2006 Standard.

The LT-310 Series' works on the same principles as the high integrity LT- 210 Series Resistivity and is selected where 1-6 probe channels are required. A single probe can be utilized to provide a control signal or several can be paired and validated against each other where greater reliability is demanded. It offers a sensitivity that is reliably able to detect condensate down to 0.5 mS/cm² instantly.

The circuits are in a continual state of test, with any faults reported through relay contacts and a visual indicator mounted on the front panel. The system can be set up such that no failed individual probe or component can cause a false signal, thereby always maintaining the critical functionality of the probes.

STANDARD FEATURES

Questtec includes a number of standard features in all TWIP products to ensure easy operation and maintenance. Standard features include: Alarms & Validated Tripping Relays, Normally Energized or Deenergized Relays, Time Delays, Sensitivities Settings, LED flash. All are easily set with solder pads in the field or by Questtec before delivery. Products also include an electronics integrity test button that tests the entire system's operation.

TWIP applications are standard in many respects, but engineered pressure parts are typically custom built to customer specifications to minimize installation costs. Trust Questtec's high quality equipment to provide TWIP so you can operate your steam turbines safely and efficiently.

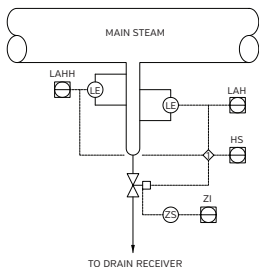
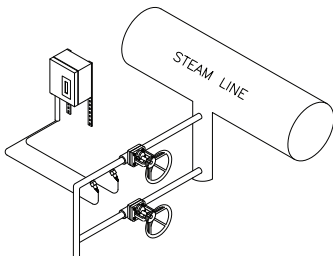
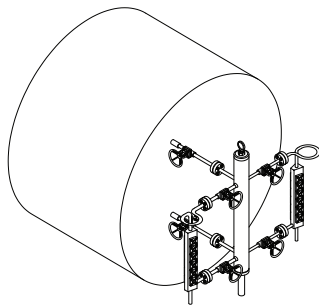
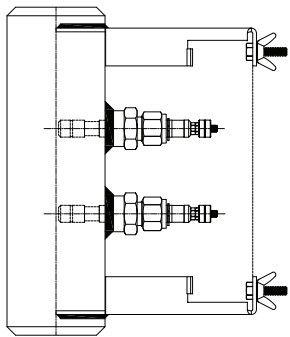

LEVEL-TRAC & STEAM-TRAC

DIRECT READING GAGES

The Questtec Steam-Trac product line fully complies with the ASME Section I requirement for Direct Reading Gage Glass. Steam-Trac products are designed specifically for the rigorous service condition of steam generation, and consistently yield lower maintenance cost than competitive products.

350 PSI



ST-350

Chamber: A-696 GR.C, Carbon Steel
Gasket: Grafoil® GHR
Glass: Tempered Borosilicate
Cover: Forged Carbon Steel
U-Bolts: A193-B7 Nickel Plated
Nuts: A194-2H Nickel Plated
Spring Washers: 17-7 PH SST Nickel Plated

450 PSI



ST-450

Chamber: A-696 Grade C Carbon Steel
Gasket: Grafoil® GHR
Shield: HQ Mica
Glass: Tempered Borosilicate
Cover: Forged Carbon Steel
Studs: A193-B7 Nickel Plated
Nuts: A194-2H Nickel Plated
Spring Washers: 17-7 PH SST Nickel Plated

1000 PSI



ST-1000

Chamber: A-105 Carbon Steel
Gasket: Grafoil® GHR
Shield: HQ Mica
Glass: Tempered Borosilicate
Cover: Forged Carbon Steel
Studs: A193-B7 Nickel Plated
Nuts: A194-2H Nickel Plated
Spring Washers: 17-7 PH SST Nickel Plated

1600 PSI



ST-1600

Chamber: A516 Grade 70 Carbon Steel
Gasket: Grafoil® GHR
Shield: HQ Mica
Glass: Tempered Borosilicate
Cover: A516 Carbon Steel
Studs: A193-B7 Nickel Plated
Nuts: A194-2H Nickel Plated
Spring Washers: 17-7 PH SST Nickel Plated

3000 PSI



STB-3000

MASTER-CLASS PRODUCT

Chamber: 304 SS Single-piece Extruded
Gasket: Spiral Wound Grafoil
Shield: Ruby HQ Mica
Glass: Tempered Aluminosilicate
Cover: Carbon Steel
Bolts: A193-B7 Nickel Plated
 Bi-color Illuminator Required



SLI-A SEE-LEVEL ILLUMINATOR FOR STEAM SERVICE

Lighting: Amber LED's angled at 45° for easy viewing of meniscus
Power Supply: 115/230 VAC @ 50/60 HZ
Power Consumption: <150 mA @ 115 VAC
Supply Connection: 3/4 NPT
Ambient Temp: -40°F [-40°C] to 150°F [65°C]
LED Estimated Life: 100,000 hours
Certification: UL1203, UL913, CSA22.2, CL I, DIV 1, Groups B, C, & D, NEMA 4X & 8
Savings: One Power Supply will illuminate four sections



STBI-3000A BI-COLOR ILLUMINATOR

Power Supply: 84-264 VAC
Power Consumption: 0.24 Amps per 5 Ports
Power Supply Enclosure: NEMA 4X, Anodized Aluminum
Lighting: Long Life, Low Current, High Intensity LED Lamps
Material: Anodized Aluminum
Connection Type: Quick Connect Latches for Ease of Assembly

SPARE PARTS

Kits including glass, gaskets, cushions and shields are available for repair of Questtec or OEM direct reading gages.



Gaskets, cushions, glass & shields for reflex and transparent style gages

Glass, Gaskets, Cushions, & Mica Shields for STB-3000 Bi-Color Ported Gage

LEVEL-TRAC & STEAM-TRAC

CUSTOM DESIGNED LEVEL MEASUREMENT PRODUCTS



ST-450 with Illuminator and Equalizer Tube



ST-350 with Magne-Trac Magnetic level Gage



316 SS STB-3000



ST-1000 and Illuminator with Bridle-Trac and Guided Wave Radar

VALVES

Questtec Solutions steam valves are designed specifically for use with water level gages in steam/water service. The angled flow path compactly facilitates installation of the level gage, bringing the assembly connection point to the side. Each model is designed to prevent steam galling and maximize packing life to extend the longevity of the valve.

450 PSI



SV-450

Offset Pattern
Grafoil Packing for Temperatures to 700°F
Screwed Bonnet
Removable Seat
Eccentric Union Tank Connector
Optional Back-seating Stem

VALVE OPTIONS

Gasketed Union Gage
Connection to allow rotation of viewing angle
Quick-Closing Levers
Chainwheel Operation
Vertical Rising Ball Check

1100 PSI



SV-1100

Offset Pattern
Outside Screw & Yoke (OS&Y) Design
Non-Union Solid Shank Tank Connector
Bolted Bonnet
Grafoil Packing for Temperatures to 700°F
Non-rotating Back-seating Stem

GAGE OPTIONS

Isolation or Drain Valves per customer requirements
Gasketed Union Gage
Connection to allow rotation of viewing angle
Stainless Steel Construction for Offshore or Corrosive Environments
Center Tie-Tube to Meet Any Visible Range

1600 PSI



SV-1600

Offset Pattern
Outside Screw & Yoke (OS&Y) Design
Non-Union Solid Shank Tank Connector
Bolted Bonnet
Grafoil Packing for Temperatures to 700°F
Non-rotating Back-seating Stem

COLUMN OPTIONS

Isolation or Drain Valves per customer requirements
Pre-wired, Integral Mounted Junction Box
Alternate Materials Available for Corrosive Environments and Extreme Temperatures

3000 PSI

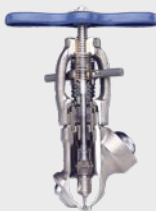

SV-3000

Outside screw & yoke design
Back Seating Stem
Graphite packing
High performance packing system
Integral Gland Wrench
Clampseal Bonnet/Chamber

READY TO SPEC?

The following is an overview of **Questtec Solution's** standard steam products. For more in depth information, contact your Questtec Sales Representative. You can also contact Questtec directly by phone at 866-240-9906, by email at sales@qtslevel.com, or online at www.qtslevel.com.

LEVEL-TRAC & STEAM-TRAC

INDIRECT GAGES

Questtec Solutions Level-Trac products are designed exclusively to sense water in steam generation process. Level-Trac systems include remote water level indicators per ASME Section I and turbine water induction protection.

1000 PSI



LT-500

Chamber: SA-105 Extruded
Probe Mounting: Horizontal
Probe Type: Type 800
Probe Gasket: Spiral Wound



TYPE 800

Probe Rating: 1000 PSI WSP; 550°F
 Threaded Column Connection High Quality Spiral Wound Gasket
 TFE Insulator

2000 PSI



LT-501

Chamber: SA-105 Extruded
Probe Mounting: Horizontal
Probe Type: 810
Probe Gasket: Spiral Wound



PROBE 810

Probe Rating: 2000 PSI WSP; 1100°F
 Threaded Column Connection
 Helium Leak Tested
 High Quality Spiral Wound Gasket
 Zirconium Insulator
 Ceramic to Metal Vacuum Brazing

3000 PSI



LT-502

Chamber: SA-106C Schedule 160
Probe Mounting: Horizontal
Probe Type: 820
Probe Seal: Ferrule Seat



PROBE 820

Probe Rating: 4350 PSI WSP; 1040°F
 Single Hex Nut Closure
 Helium Leak Tested
 Metal-to-metal Ferrule Seat
 Zirconium/Aluminosilicate Insulator
 Ceramic to Metal Vacuum Brazing

4350 PSI



LT-502 PLUS+

Chamber: SA-106C Schedule XXS
Probe Mounting: Horizontal
Probe Type: 820
Probe Seal: Ferrule Seat

1000 –
2000 PSI



LT-40 / LT-41

Point Level Switch
 Installation Within Any Vertical Pipe Run Top/Bottom
 End Connections
 3/4" or 1", F.NPT or SW
 Chamber: A-106C Carbon Steel
 No. of Probes: 1-2
 Rating: 1,000 PSI [LT-40] 2,000 PSI [LT-41]
 [Recommended Control Unit: LT-310]



OEM ENHANCED PERFORMANCE KITS

Level-Trac probe replacement kits offer a better value as compared to original equipment manufacturers. Enhanced Performance kits are available for manufacturers such as:
 Clark Reliance
 Yarway/Fossil
 Diamond Power
 Hydrastep

READY TO SPEC?

The following is an overview of **Questtec Solution's** standard steam products. For more in depth information, contact your Questtec Sales Representative. You can also contact Questtec directly by phone at 866-240-9906, by email at sales@qtslevel.com, or online at www.qtslevel.com.

LEVEL-TRAC & STEAM-TRAC

ELECTRONIC CONTROL UNITS



LT-100 SERIES

Probe Channels: 1 - 12
Relays: All Channels
Power Supply: Single 120
240 VAC

Enclosure: NEMA 4X
Fiberglass Reinforced
Polyester
Features: Plug-In
Detection Modules



LT-210

Probe Channels: 1 - 12
Relays: 2 Alarms, 2
Validated Trips, 1 Fault,
8A DPDT
Power Supply: Single
100-240 VAC
Output Power: 4-20mA,
Remote Display

Enclosure: NEMA 4X
Fiberglass Reinforced
Polyester
Features: Sequence Fault
Detection
Door mounted LED
indicator

MASTER-CLASS PRODUCT



LT-220

Probe Channels: 1 - 14
Relays: 2 Alarms, 2
Validated Trips, 1 Fault 8A
DPDT
Power Supply: Dual
100-240 VAC
Output Power: 4-20mA,
Remote Display

Enclosure: NEMA 4X
Fiberglass
Reinforced Polyester
Features: Sequence Fault
Detection Door mounted
LED indicator

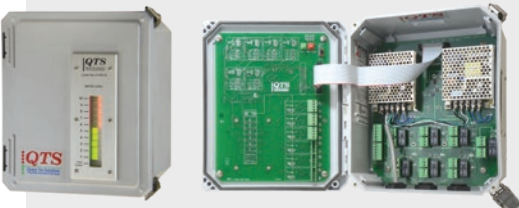

LT-310

Probe Channels: 1 - 6
Relays: Alarm/Trip Relays
used individually or in
validation, 6 8A DPDT
Power Supply: Dual,
100-240 VAC

Output Power: Remote
Display
Enclosure: NEMA 4X
Fiberglass Reinforced
Polyester
Features: Door mounted
LED indicator Solid State
Circuitry



REMOTE INDICATORS

Each of these electronic units are available with remote indicators. These remote indicators come with individual channel wiring and the LT-210 and LT-220 models have an option for serial transmission.

HIGH TEMPERATURE CABLING

Our cable is designed specifically for use with Level-Trac Remote Level Indicator Systems for connection of the probe column to the control unit. The probe side will be terminated with high temperature, nickel plated steel, un-insulated ring terminals for connection to the probes and common lug.

LEVEL-TRAC & STEAM-TRAC

SYSTEM SUMMARY

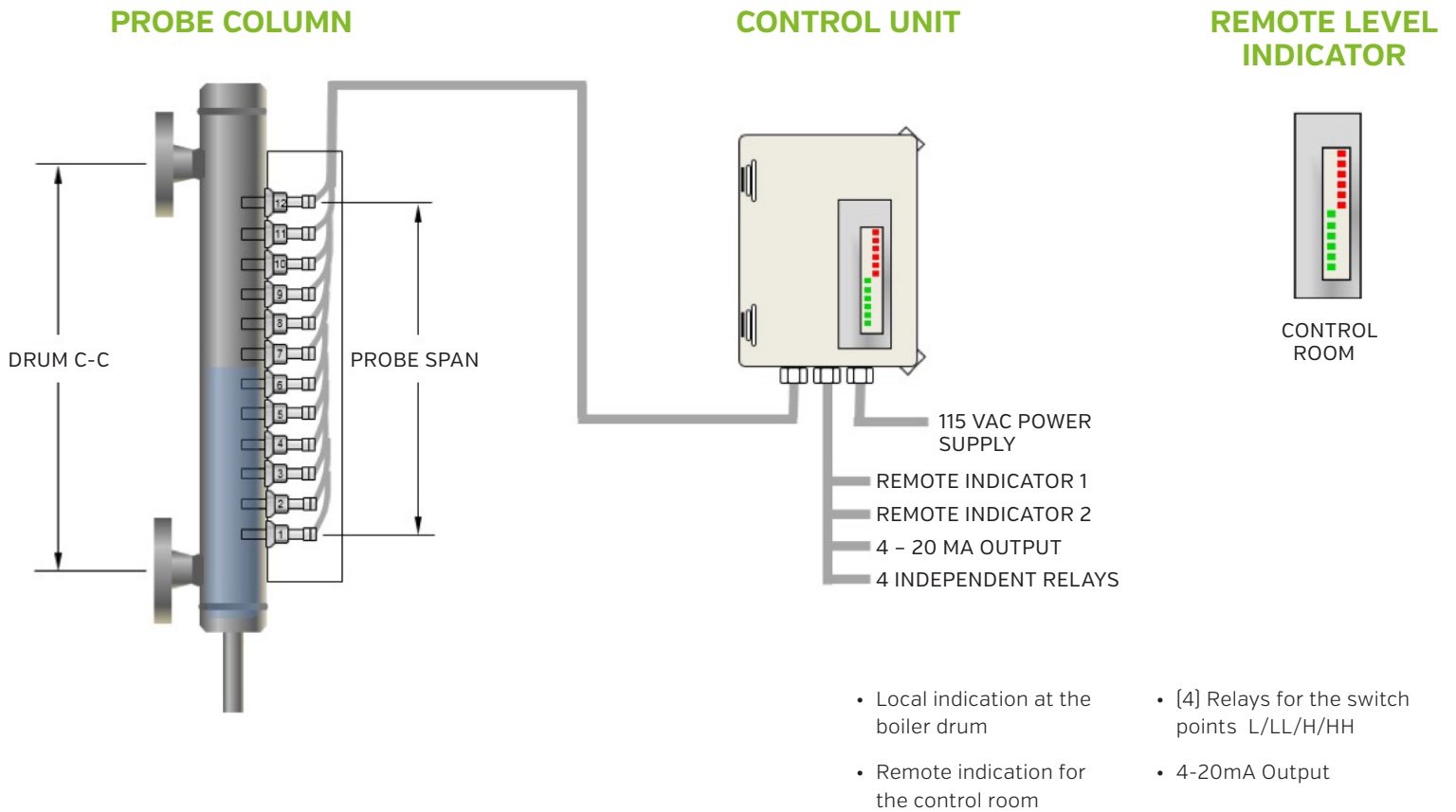

Questtec
SOLUTIONS

13960 S. Wayside, Houston, Texas 77048
Toll Free: 866.240.9906 | Tel: 281.240.0440 | Fax: 281.240.2440
sales@QTSLevel.com

WWW.QTSLEVEL.COM

200-00 10/17

ASME "S" & "R"
Stamp holder



ISO 9001:
2008
Registered

ASME
SETTING THE STANDARD
1884 2003
ASME Sec. VIII
Div I BPVC
Certified
Manufacturing



CNC Precision
Machining for all
components